

nSynC-Staging Quick Start Guide



Rev A03

Getting Started

Congratulations on the purchase of an nSynC-Staging adapter! The nSynC-Staging adapter makes it possible to simultaneously charge up to four select USB-C mobile devices while accessing data from a wired network connection. This mode of operation is called SimulCharge.

The SimulCharge mode of operation charges your mobile device battery to 100% as long as external power is attached. It also supports Docking Detect, which ensures the mobile devices enter the correct state during a “hot connect” to the LAVA product.

The nSynC-Staging adapter also features an On-the-Go (OTG) mode, where the mobile devices still remain USB Hosts when plugged into the adapter so they access its network connection through the Ethernet. The devices run on battery power in this mode, while the adapter is still powered by the external power source.

The nSynC-Staging adapter provides the following features:

- Access Ethernet while simultaneously charging up to 4 mobile devices
- OTG mode
- Provide a 10/100 wired Ethernet connection to up to 4 mobile devices
- Fast Charging (where applicable)

Your hardware purchase will include:

- nSynC-Staging device

Prior to proceeding with the instructions in this document, ensure you have obtained:

- A compatible USB-C mobile device (tablet or smartphone)
- USB-C to USB-C cables which support **both data and charging**

Note: Not all USB-C mobile devices will be compatible with the nSynC-Staging in SimulCharge mode. However, almost all USB-C tablets and smartphones are capable of OTG, making the nSynC-Staging a truly universal adapter in that mode.

Hardware Setup

Requirements:

- nSynC-Staging
- USB-C to USB-C cables that support both **data and charging**
- Compatible mobile devices (such as tablets or smartphones)
- USB Charger & Charging Cable (Charger must provide at least 45 watts of power for SimulCharge mode to work.)

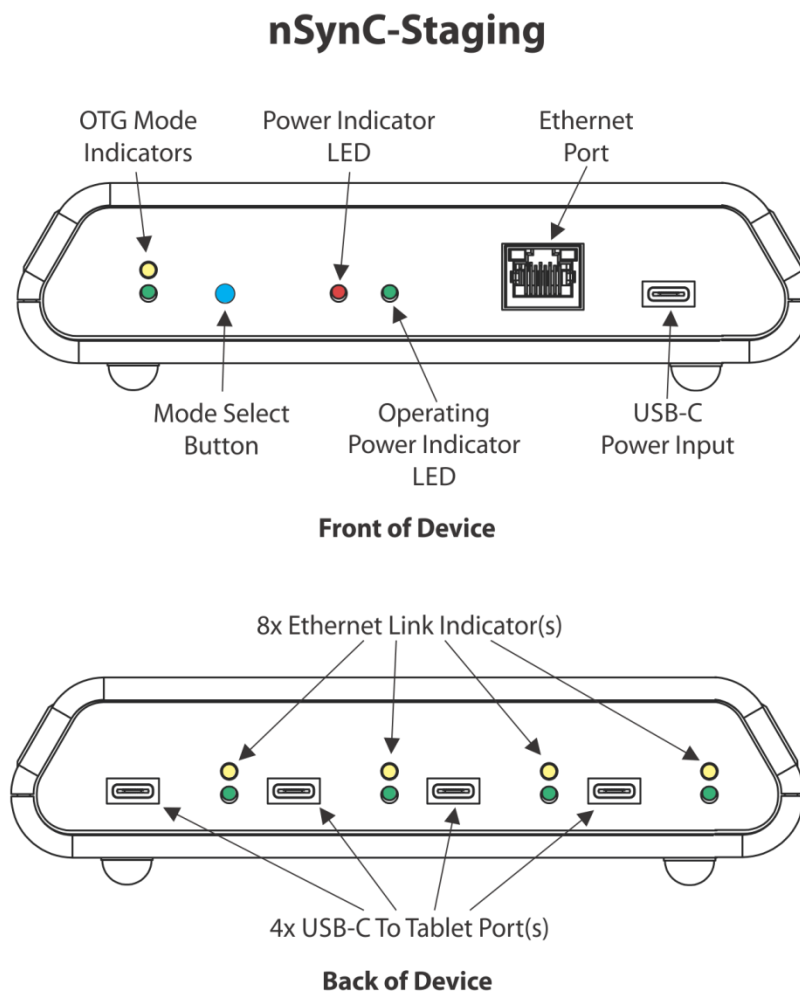

Figure 1: Standard connection of nSynC-Staging to mobile device

Setup Procedure:

1. Plug the USB Charger into an AC power source and connect the USB-C connector into the port marked "USB-C Power Adapter".
2. Once the product is powered, the red power status LED will turn on to indicate the adapter is receiving power. The red operating power status LED will turn on if the adapter is receiving 45 watts from the power supply. This wattage is needed for SimulCharge to work on the nSynC-Staging adapter. If the board receives less than 45 watts, it defaults to OTG mode.
3. Plug one end of each USB-C to USB-C cable into each mobile device's USB-C port, and the other end into one of the ports marked "Mobile Device Data & Power Output".
4. Plug your Ethernet cable into the network. Each of these USB-C ports have a green and yellow status LED that flash when the connected mobile device is receiving data through the adapter's wired network connection.

Wired Ethernet Configuration (for Ethernet-capable products)

Depending on the mobile devices and network configuration, you may need to enable or reconfigure the wired connection settings on one or more of the mobile devices.

After establishing a connection with the nSynC-Staging adapter, the Ethernet configuration option should be available in the Settings menu of each mobile device (i.e. Settings > Connections > More connection settings > Ethernet).

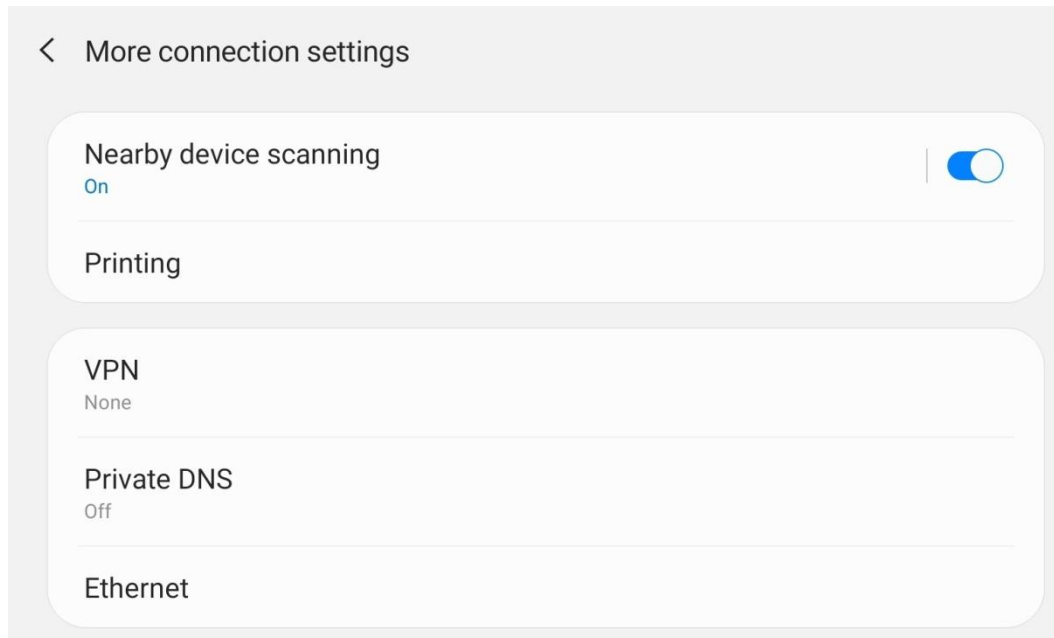

Figure 2: More connection settings on mobile device

If, after establishing a connection with the nSynC adapter, the Ethernet option is greyed out or unavailable, that mobile device likely does not support a wired connection. If this is the case, there is likely nothing that can be done to enable this feature on that mobile device.

Assuming that the Ethernet option is available, it may be necessary to enable or disable the wired connection on the mobile devices. This can be done by ensuring the Ethernet option is selected (i.e. enabling the connection) or deselected (i.e. disabling the connection) on the Ethernet page.

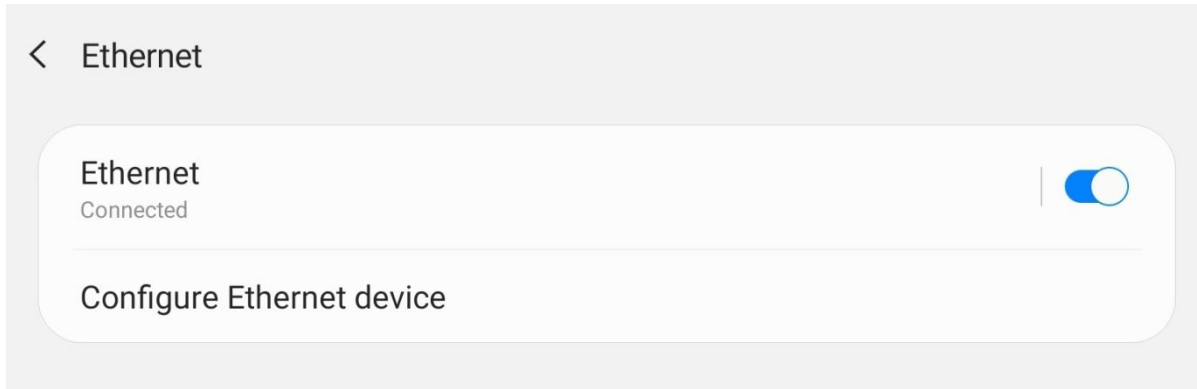

Figure 3: Ethernet enabled on mobile device

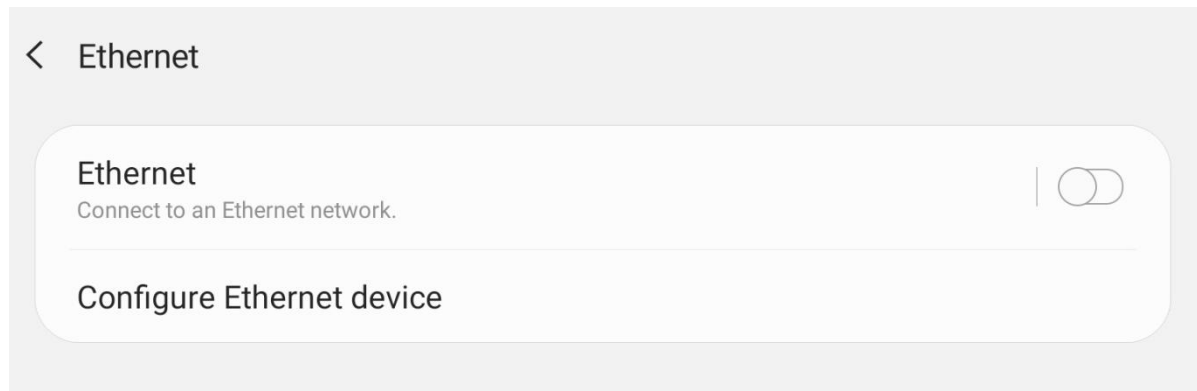

Figure 4: Ethernet disabled on mobile device

Most mobile devices will have DHCP enabled by default. If your network does not have a valid DHCP server, you will need to manually configure IP Addresses for the devices.

To manually configure an IP Address, you will need to disable the Ethernet connection on the Ethernet page before selecting "Configure Ethernet Device". From here, you can select "Static IP" and specify the IP Address settings to be used by the mobile device.

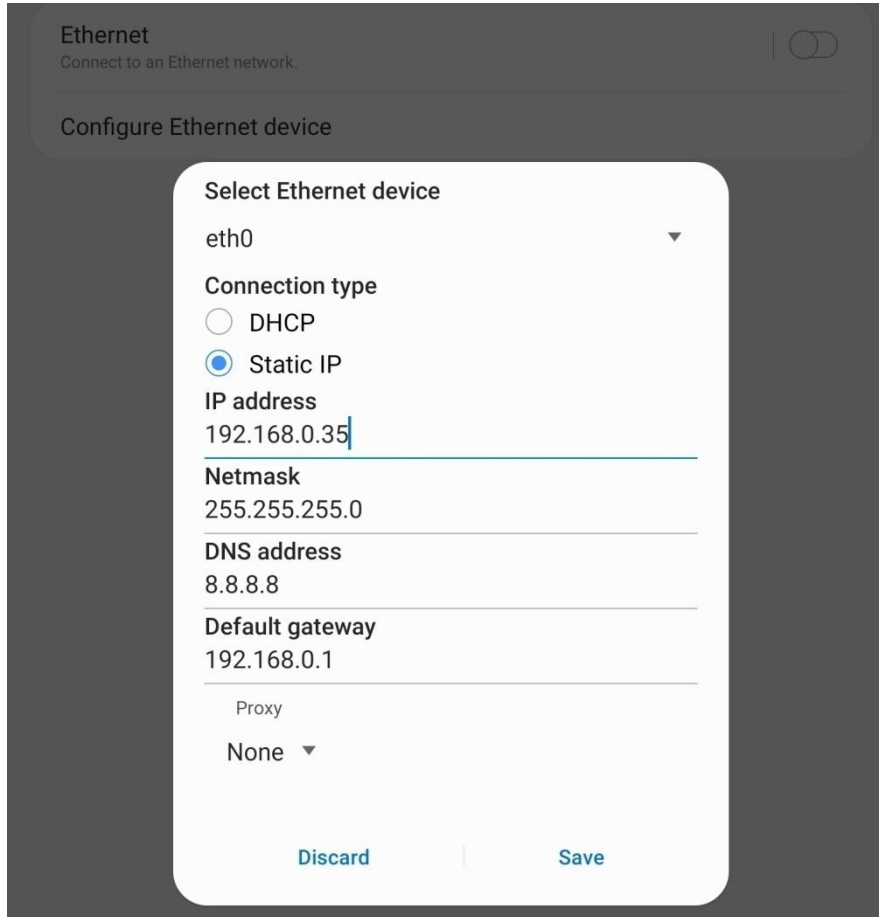

Figure 5: Example of Static IP configuration on a mobile device

Once the IP Address has been configured, you will need to re-enable the connection on the Ethernet page in order to use the wired connection.

LAVA

Technical Support

9:00 am to 5:00 pm Monday to Friday (Eastern Time)

Tel: +416 674-5942

Toll Free (US & Canada): 1-800-241-5282

E-mail: tech@lavalink.com

Web: www.lavalink.com



This device complies with part 15 of the FCC Rules. Operation is subject to the following conditions: (1) This device may not cause harmful interference, and (2) this device must accept any interference received, including interference that may cause undesired operation.

Lava Computer MFG Inc. 908 Niagara Falls Blvd. #629. North Tonawanda NY 14120-2060